



Package Contents



GBE



Ball Joint Mount



Lock Ring



Metal Strap



Gigabit PoE (24V, 0.5A) with
Mounting Bracket



Power Cord

Installation Requirements

- Clear line of sight between GigaBeam AP and station
- Pole-mounting: 7 mm socket wrench or screwdriver
- Wall-mounting: wall fastener (not included)
- Shielded Category 5 (or above) cabling with drain wire should be used for all wired Ethernet connections and should be grounded through the AC ground of the PoE.

We recommend that you protect your networks from harmful outdoor environments and destructive ESD events with industrial-grade, shielded Ethernet cable from Ubiquiti. For more details, visit ui.com/toughcable

- Surge protection should be used for all outdoor installations. We recommend that you use two Ethernet Surge Protectors, model ETH-SP-G2, one near the device and the other at the entry point to the building. The ETH-SP-G2 will absorb power surges and safely discharge them into the ground.



Note: For guidelines about grounding and lightning protection, follow your local electrical regulatory codes.



GBE Quick Start Guide

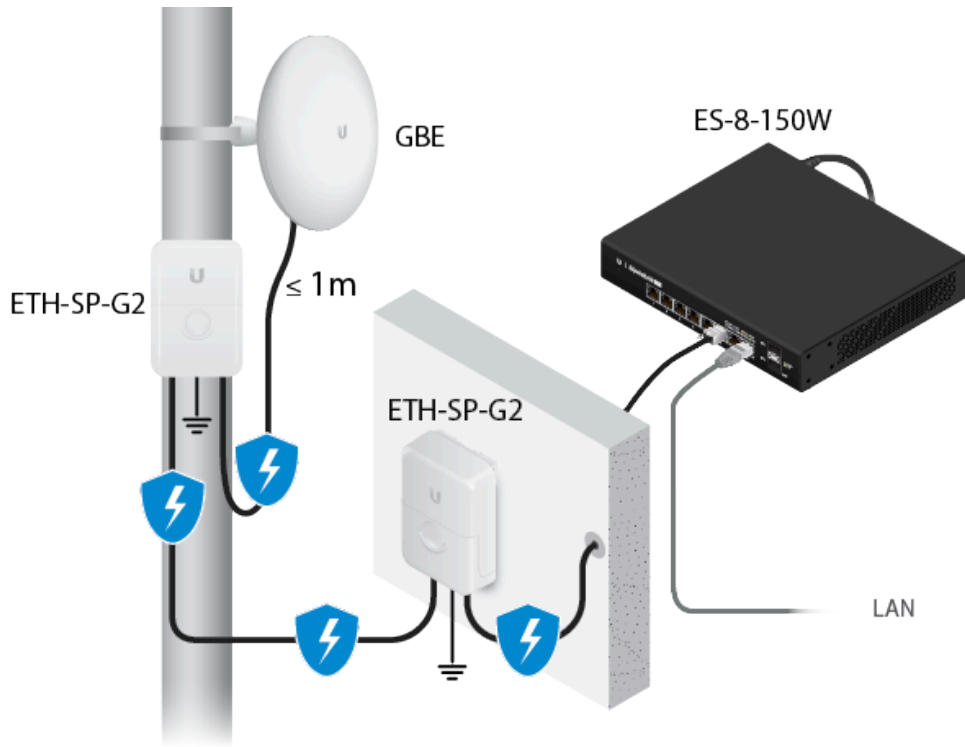

Hardware Overview

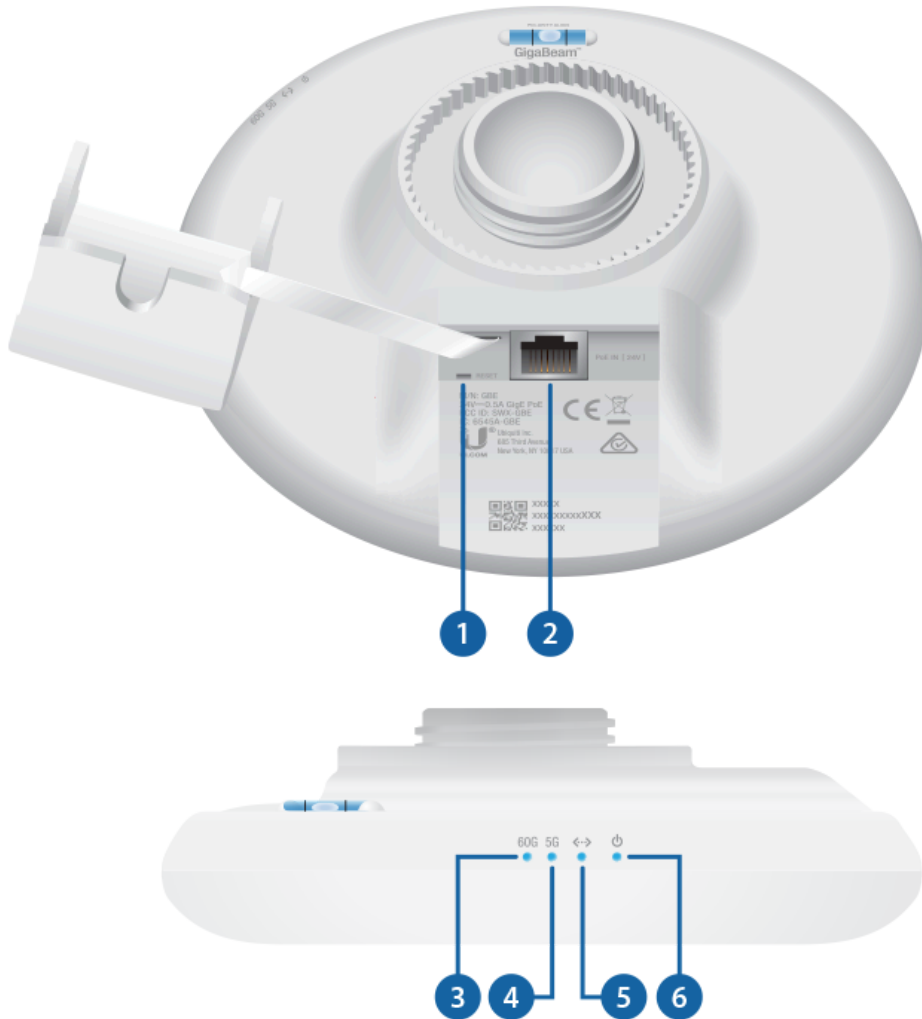

To reset to factory defaults, press and hold the Reset button for more than 10 seconds while the device is powered on. Alternatively, the device may be reset remotely via a Reset button located on the bottom of the Gigabit PoE Adapter.

2 PoE IN Port

This Gigabit Ethernet port is used to connect the power and should be connected to the LAN and DHCP server.

3 60 GHz LED

Lights steady blue when 60 GHz link is ready.

4 5 GHz LED

Lights steady blue when the 5 GHz link is ready.

5 LAN LED

The LED will light steady blue when an active Ethernet connection is made to the Ethernet port and flash when there is activity.

6 Power/Status LED

Flashing White	Bootup in progress.
White	Ready for use, not connected to Ubiquiti Internet Service Provider (UISP™). See “UISP Management” .
Blue	Ready for use, connected to UISP.
Steady Blue with Occasional Flashing	Ready for use, unable to connect to UISP, check connection to UISP server.
Quickly Flashing Blue	Used to locate a device in UISP.
Alternating Blue/White	Firmware upgrade in progress.

Hardware Installation

Go to the appropriate mounting instructions: Pole Mounting or [“Wall Mounting”](#).

Pole-Mounting



GBE Quick Start Guide

2.

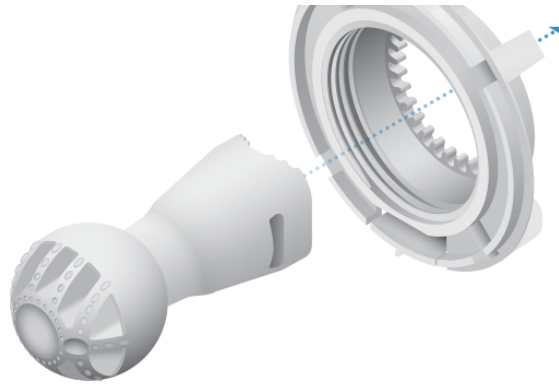

3.

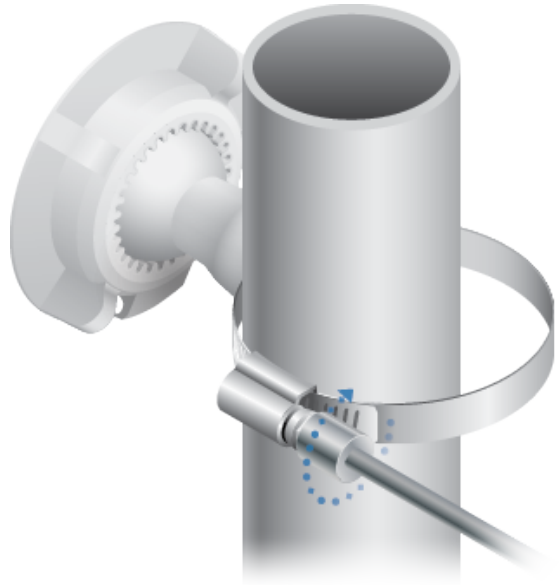
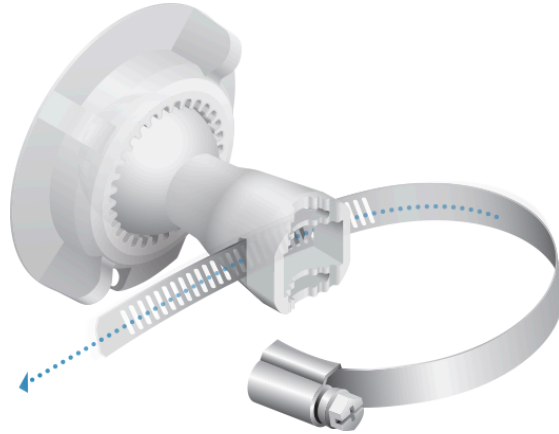



Wall Mounting

The device must be mounted directly to a wood stud or other structurally stable surface to avoid damage to the mounting hole when you adjust the aim.

Optional Accessory

To enhance stability, you can use the NanoBeam® Wall Mount Kit, model NBE-WMK (sold separately).

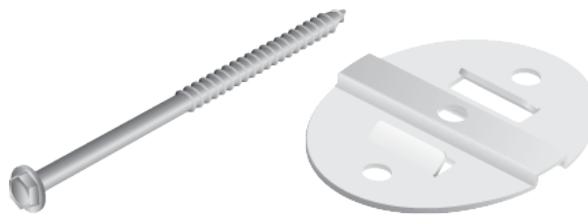

Note: Center screw included. Two optional screws (not included) provide additional stability.

Installation Instructions



GBE Quick Start Guide

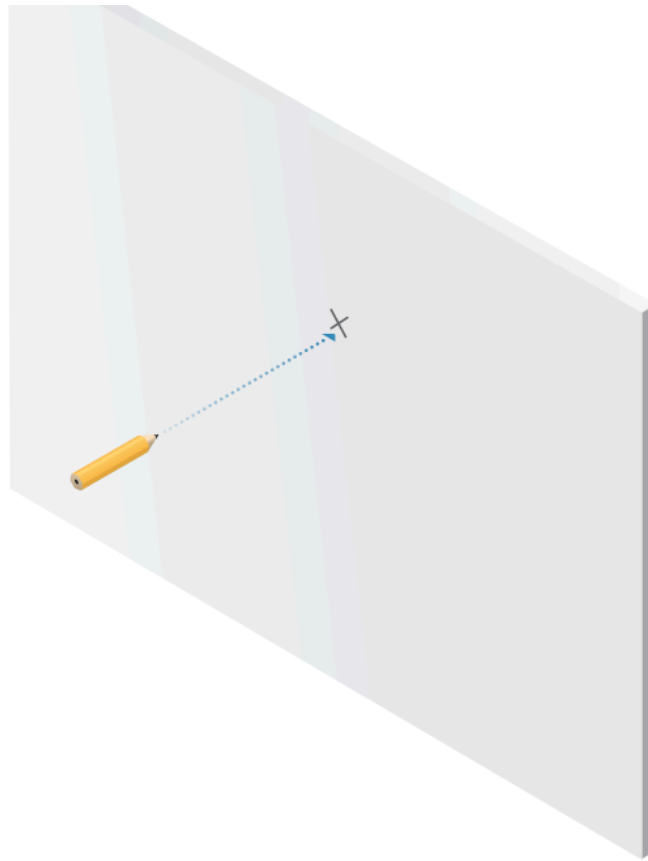

2.

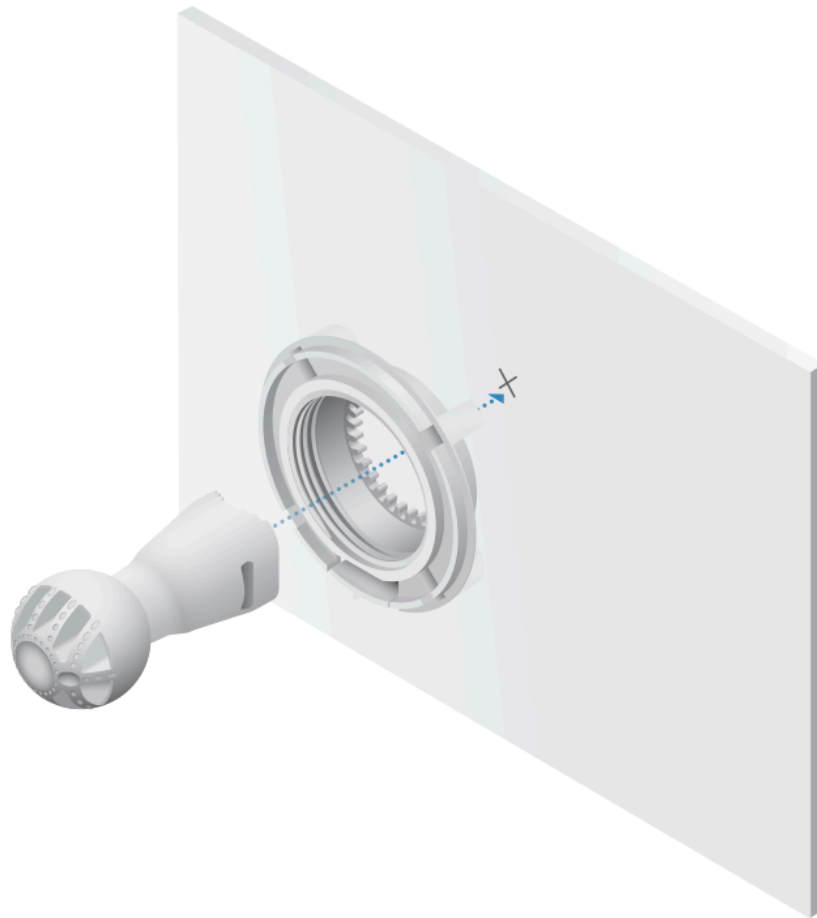

3.

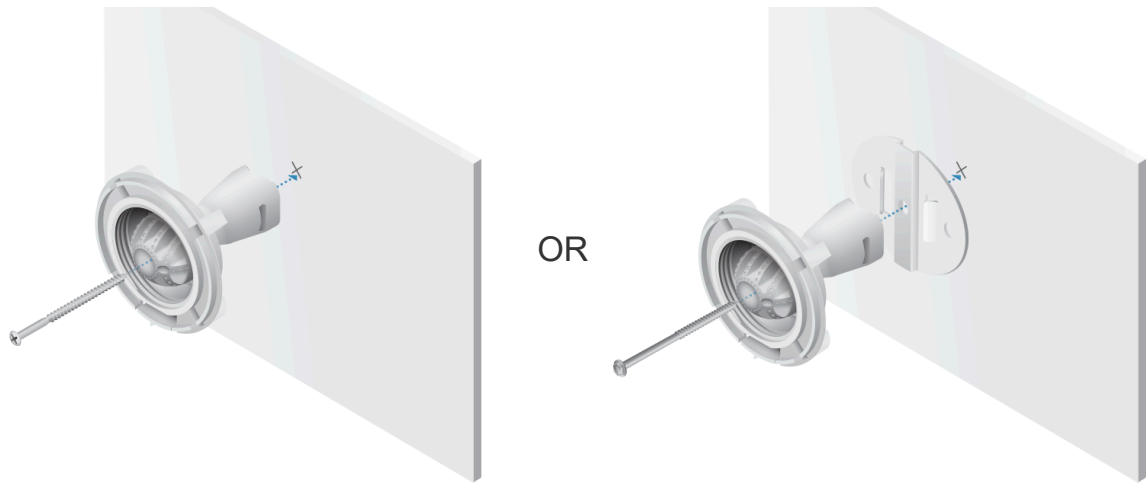

OR

Fastener (not included)

NanoBeam Wall Mount Kit

4.

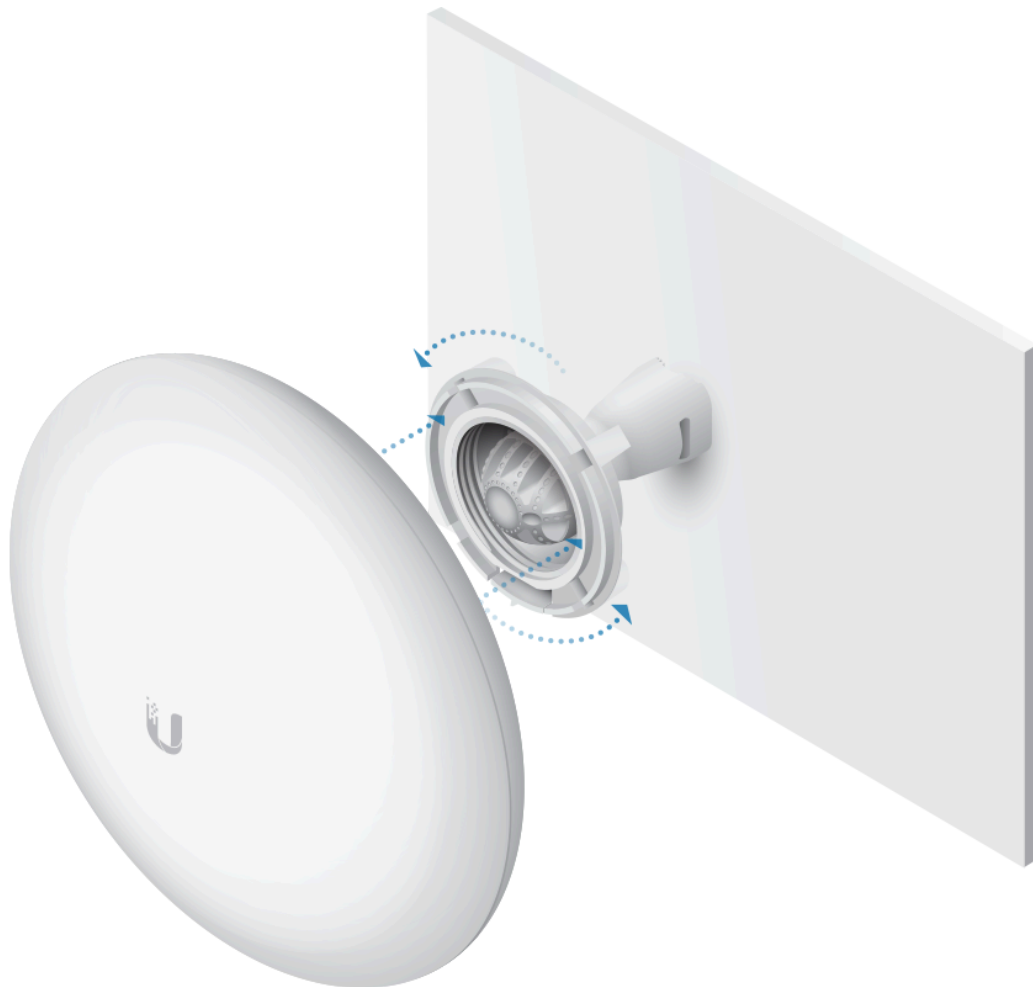

Aiming

Visually aim the GigaBeam radios at each other.



GBE Quick Start Guide

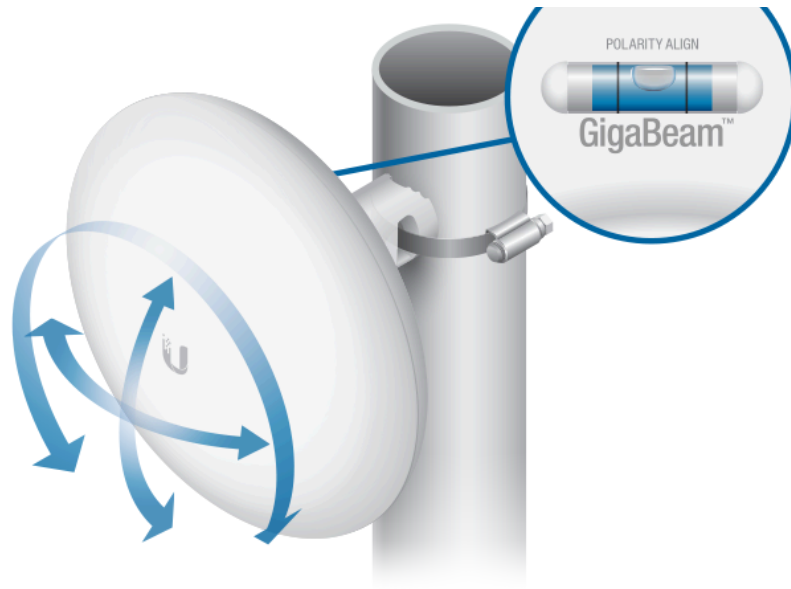

2.

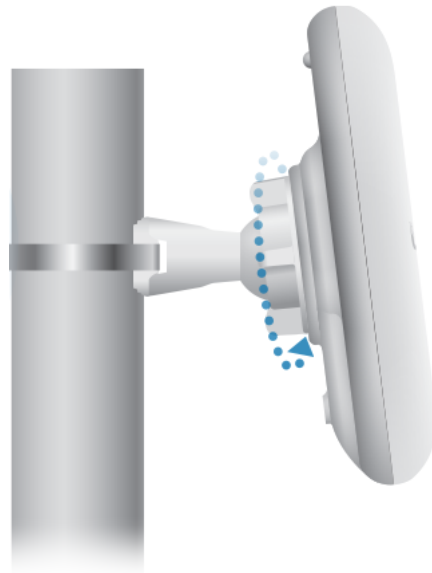

Connecting Power



GBE Quick Start Guide



2.





4.



WARNING: The switch port must comply with the power specifications listed in [“Specifications”](#).



OR



Optional



GBE Quick Start Guide

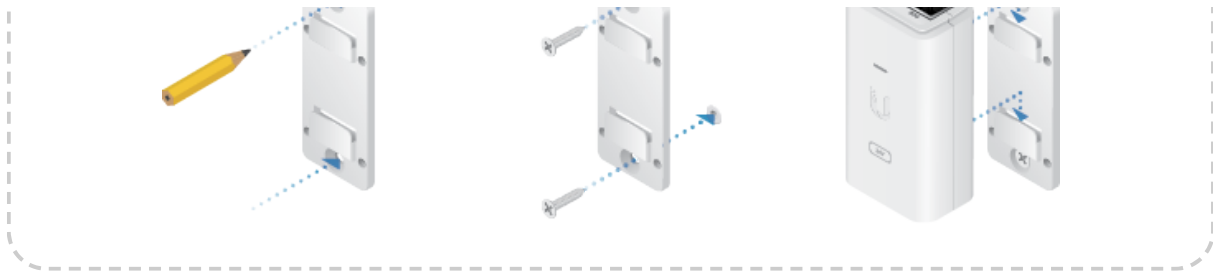

Configuration

The device is set to DHCP by default, so it will try to automatically obtain an IP address. If that fails, it will use the default fallback IP address, 192.168.1.20. Proceed to the appropriate section, DHCP or [“Fallback IP Address”](#):

DHCP

Use one of the following methods:

- Set up the DHCP server to provide a specific IP address to the device based on its MAC address (on the label).
 - Let the device obtain an IP address and then check the DHCP server to see which IP address was assigned.
1. Connect a computer to your network and configure the Ethernet adapter on your computer with a static IP address on the 192.168.1.x subnet.
 2. Launch your web browser. In the address field, type: `https://192.168.1.20`
Then press enter (PC) or return (Mac).



3. Select your Country and Language. You must agree to the Terms of Use to use the product. Click Continue.
4. Enter a Username and Password, confirm the Password, and click Save.
5. Click the  icon.
6. Configure the following settings:
 - a. For one device, enable Access Point mode. For the other device (the Station), keep Access Point disabled.
 - b. Enter a name in the SSID field. This must be the same on both the AP and the Station.
 - c. In the WPA2 Preshared Key field, enter a combination of alphanumeric characters (0-9, A-Z, or a-z).



Note: The key is an alphanumeric password between 8 and 63 characters long.

7. Click Save Changes.



b. Review the Network settings to ensure that each device has a unique IP address. Each can get its IP address via DHCP, or use a static IP address.

- **DHCP** By default DHCP client is enabled; if there is a DHCP server on your network, the device will receive its address via DHCP.



Note: If DHCP client fails, the device will use the fallback IP address: 192.168.1.20

- **Static** Select this option to disable the DHCP client and enter a static IP address.

c. Click Save Changes.

Fallback IP Address

1. Ensure that your computer (or other host machine) is connected to the same LAN as the GigaBeam.
2. Configure the Ethernet adapter on your host system with a static IP address on the 192.168.1.x subnet.
3. Launch your web browser. Type `https://192.168.1.20` in the address field, and press enter (PC) or return (Mac).



4. Select your Country and Language. You must agree to the Terms of Use to use the product. Click Continue.
5. Enter a Username and Password, confirm the Password, and click Save.
6. Click the  icon.
7. Configure the following settings:
 - a. For one device, enable Access Point mode. For the other device (the Station), keep Access Point disabled.
 - b. Enter a name in the SSID field. This must be the same on both the AP and the Station.
 - c. In the WPA2 Preshared Key field, enter a combination of alphanumeric characters (0-9, A-Z, or a-z).



Note: The key is an alphanumeric password between 8 and 63 characters long.

8. Click Save Changes.
9. Configure each device (AP and Station) with a unique IP address:
 - a. Click the  icon.
 - b. Review the Network settings to ensure that each device has a unique IP address. Each can get its IP address via DHCP, or use a static IP address.



Note: If DHCP client fails, the device will use the fallback IP address: 192.168.1.20

- **Static** Select this option to disable the DHCP client and enter a static IP address.

c. Click Save Changes.

Repeat the instructions in the [“Configuration”](#) section on the other GigaBeam.

UISP Management

You can manage your device using UISP, which lets you configure, monitor, upgrade, and back up your devices using a single application. Get started at uisp.ui.com

Installer Compliance Responsibility

Devices must be professionally installed and it is the professional installer’s responsibility to make sure the device is operated within local country regulatory requirements.

The 5GHz Output Power field is provided to the professional installer to assist in meeting regulatory requirements.

Specifications

GBE	
Dimensions	140 x 140 x 44 mm (5.51 x 5.51 x 1.73)
Weight	376 g (13.3 oz)
Enclosure	UV-Resistant Polycarbonate
Gain	
5 GHz	10 dBi
60 GHz	17.2 dBi
Networking Interface	10/100/1000 Ethernet Port Wi-Fi for Management
Max. Power Consumption	11W
Power Method	Passive PoE (Pairs 4, 5+; 7, 8-)
Power Supply	24V, 0.5A Gigabit PoE Adapter (Included)
Mounting	Pole-Mount (Kit Included) Wall-Mount (Not Included)
ESD/EMP Protection	± 24kV Contact/Air
Operating Temperature	-40 to 60° C (-40 to 140° F)



GBE Quick Start Guide

Operating Humidity	5 to 95% Noncondensing	
Certifications	CE, FCC, IC	
Radio		
Max. Conducted TX Power 5/60 GHz Combined	25 dBm	
Channel Bandwidth 60 GHz 5 GHz	2160 MHz 20/40/80 MHz	
Operating Frequency (GHz)		
Worldwide	5.180 - 5.875 57 - 66	
US/CA	U-NII-1	5.180 - 5.250
	U-NII-2A	5.250 - 5.350
	U-NII-2C	5.470 - 5.725
	U-NII-3	5.725 - 5.850
		57 - 66
Management Radio (MHz)		
Worldwide	2412 - 2472	
US/CA	2412 - 2462	

Safety Notices

1. Read, follow, and keep these instructions.
2. Heed all warnings.
3. Only use attachments/accessories specified by the manufacturer.



WARNING: Do not use this product in location that can be submerged by water.



WARNING: Avoid using this product during an electrical storm. There may be a remote risk of electric shock from lightning.

Electrical Safety Information

1. Compliance is required with respect to voltage, frequency, and current requirements indicated on the manufacturer's label. Connection to a different power source than those specified may result in improper operation, damage to the equipment or pose a fire hazard if the limitations are not followed.
2. There are no operator serviceable parts inside this equipment. Service should be provided only by a qualified service technician.



GBE Quick Start Guide

- a. Do not substitute the power cord with one that is not the provided approved type. Never use an adapter plug to connect to a 2-wire outlet as this will defeat the continuity of the grounding wire.
- b. The equipment requires the use of the ground wire as a part of the safety certification, modification or misuse can provide a shock hazard that can result in serious injury or death.
- c. Contact a qualified electrician or the manufacturer if there are questions about the installation prior to connecting the equipment.
- d. Protective earthing is provided by Listed AC adapter. Building installation shall provide appropriate short-circuit backup protection.
- e. Protective bonding must be installed in accordance with local national wiring rules and regulations.

Limited Warranty

ui.com/support/warranty

The limited warranty requires the use of arbitration to resolve disputes on an individual basis, and, where applicable, specify arbitration instead of jury trials or class actions.

Compliance

FCC

Changes or modifications not expressly approved by the party responsible for compliance could void the user's authority to operate the equipment.

This device complies with Part 15 of the FCC Rules. Operation is subject to the following two conditions.

1. This device may not cause harmful interference, and
2. This device must accept any interference received, including interference that may cause undesired operation.

This equipment has been tested and found to comply with the limits for a Class A digital device, pursuant to part 15 of the FCC Rules. These limits are designed to provide reasonable protection against harmful interference when the equipment is operated in a commercial environment. This equipment generates, uses, and can radiate radio frequency energy and, if not installed and used in accordance with the instruction manual, may cause harmful interference to radio communications. Operations of this equipment in a residential area is likely to cause harmful interference in which case the user will be required to correct the interference at his own expense.

This radio transmitter has been approved by FCC.

ISED Canada

CAN ICES-3(A)/NMB-3(A)

This device complies with ISED Canada licence-exempt RSS standard(s). Operation is subject to the following two conditions:

1. This device may not cause interference, and



GBE Quick Start Guide

This radio transmitter has been approved by ISED Canada.

The device for operation in the band 5150-5250 MHz is only for indoor use to reduce the potential for harmful interference to co-channel mobile satellite systems.

CAN ICES-3(A)/NMB-3(A)

Le présent appareil est conforme aux CNR d'ISDE Canada applicables aux appareils radio exempts de licence. L'exploitation est autorisée aux deux conditions suivantes :

1. l'appareil ne doit pas produire de brouillage;
2. l'appareil doit accepter tout brouillage radioélectrique subi, même si le brouillage est susceptible d'en compromettre le fonctionnement.

Le présent émetteur radio a été approuvé par ISDE Canada.

Les dispositifs fonctionnant dans la bande 5150-5250 MHz sont réservés uniquement pour une utilisation à l'intérieur afin de réduire les risques de brouillage préjudiciable aux systèmes de satellites mobiles utilisant les mêmes canaux.

IMPORTANT NOTE

Radiation Exposure Statement

- This equipment complies with radiation exposure limits set forth for an uncontrolled environment.
- This equipment should be installed and operated with minimum distance 33 cm between the radiator and your body.
- This transmitter must not be co-located or operating in conjunction with any other antenna or transmitter.

AVIS IMPORTANT

Déclaration sur l'exposition aux rayonnements

- Cet équipement est conforme aux limites prévues pour l'exposition aux rayonnements dans un environnement non contrôlé.
- Lors de l'installation et de la mise en fonctionnement de l'équipement, assurez-vous qu'il y ait une distance minimale de 33 cm entre l'élément rayonnant et vous.
- Cet émetteur ne doit être installé à proximité d'aucune autre antenne ni d'aucun autre émetteur, et ne doit être utilisé conjointement à aucun autre de ces appareils.

Australia and New Zealand



Warning: This equipment is compliant with Class A of CISPR 32. In a residential environment this equipment may cause radio interference.

Brazil



Nota: Este equipamento não tem direito à proteção contra interferência prejudicial e não pode causar interferência em sistemas devidamente autorizados.



CE marking on this product represents the product is in compliance with all directives that are applicable to it.



Country List



AT	BE	BG	CY	CZ	DE	DK	EE	EL	ES	FI	FR	HR	HU
IE	IT	LV	LT	LU	MT	NL	PL	PT	RO	SE	SI	SK	UK

BFWA (Broadband Fixed Wireless Access) members noted in blue



Note: This device meets Max. TX power limit per ETSI regulations.



Note: Fixed service or any restrictions for authorization of use shall follow local country regulations.

The following apply to products that operate in the 5 GHz frequency range:



Note: This device is restricted to indoor use only when operating in the 5150 - 5350 MHz frequency range within all member states.



Note: All countries listed may operate at 30 dBm. BFWA member states may operate at 36 dBm.



Note: Operation in the 5.8 GHz frequency band is prohibited in BFWA member states. Other countries listed may use the 5.8 GHz frequency band.

WEEE Compliance Statement

Declaration of Conformity

Online Resources



GBE Quick Start Guide

